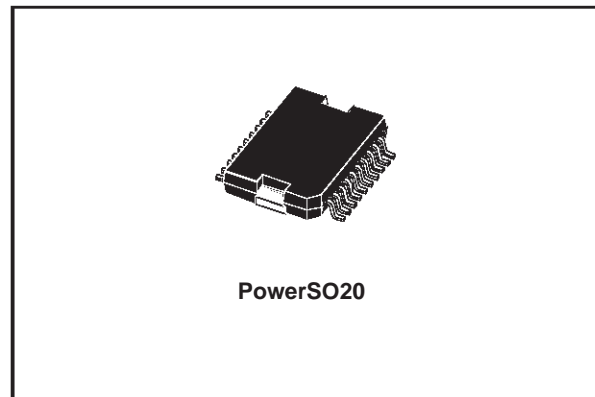
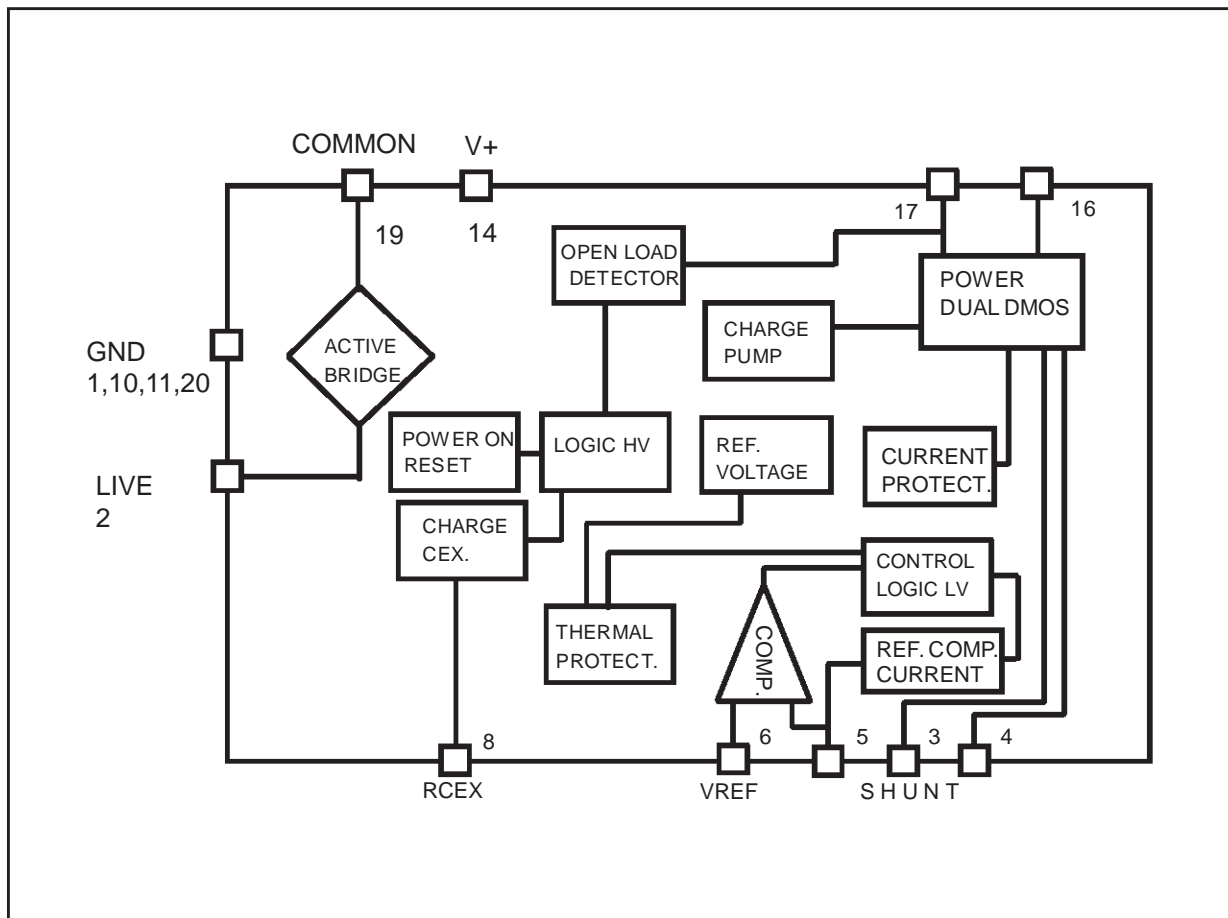

FOLDER ACTUATOR

- BIDIRECTIONAL SWITCH
- MOTOR STOP CONTROLLED BY MOTOR CURRENT
- START UP AND END CURRENT DETECTION THRESHOLDS PROGRAMMABLE WITH EXTERNAL RSHUNT
- STOP DELAY TIME FOR START UP AND END PHASE PROGRAMMABLE WITH EXTERNAL RC
- OUTPUT SHORT CIRCUIT PROTECTION
- OUTPUT CURRENT LIMITING > 8A
- THERMAL PROTECTION
- ACTIVE DIODE BRIDGE INTERNALLY DIFFUSED
- MAXIMUM VOLTAGE SUPPLY 50V

PowerSO20

- TECHNOLOGY MULTIPOWER BCD60II

BLOCK DIAGRAM

ABSOLUTE MAXIMUM RATINGS

Symbol	Parameter	Value	Unit
V_{bat}	Supply Voltage	50	V
I_{out}	Output current DC at I_s	5 6	A A
T_{op}	Operating Temperature	-40 to 125	°C

PIN CONNECTION

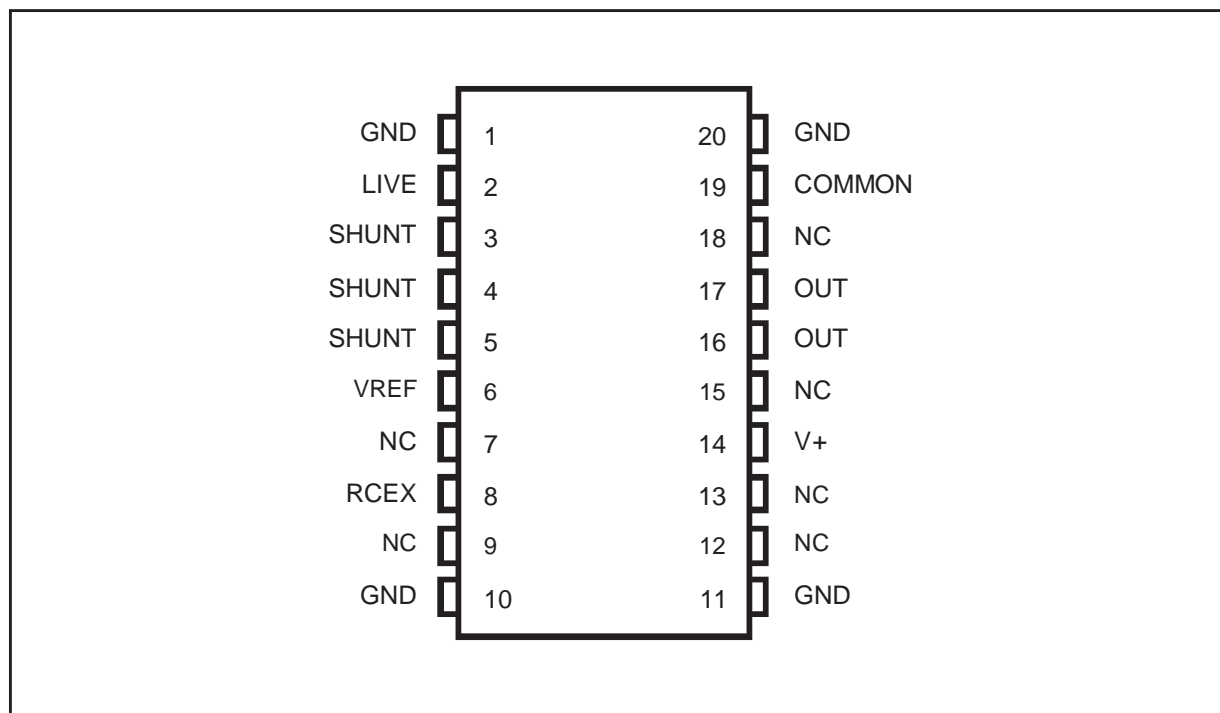

THERMAL DATA

Symbol	Parameter	Value	Unit
$R_{th\ j-case}$	Thermal Resistance Junction to case Max.	4	°C/W

ELECTRICAL CHARACTERISTICS (Refer to the test circuit, unless otherwise specified.)

Symbol	Parameter	Test Condition	Min.	Typ.	Max.	Unit
V _{bat}	Power supply		8		17	V
I _q	Quiescent current	Standby		100	200	μA
I _{ref}	Current ref. threshold for start and end current (note 1)	V _{bat} = 8 to 17V	70	100	135	μA
I _{refcc}	Current ref. threshold for short circuit current det (note 2)	V _{bat} = 8V V _{bat} = 12V V _{bat} = 17V	240 300 400	300 440 550	400 560 690	μA
I _{sc1}	Current short circuit limit		8			A
T _{dsc}	Short circuit time delay	I _{load} > I _{thcc}			100	μs
R _{on}	R _{on} output power DMOS	I _{load} = 1.2A		0.6	1	Ohm
R _{ona}	R _{on} active bridge DMOS	V _{bat} = 8V, I _{gnd} = 1A			0.7	Ohm
R _{load}	Open load detector max. load resistance				200	Ohm
K _{td}	Delay constant (note 3)			1		
Deb	Immunity debouncer switch	V _{bat} = pulse				

Note 1: $I_{th} = \frac{R_{ref}}{R_{shunt}} \cdot I_{ref}$

Note 2: $I_{thcc} = \frac{R_{ref}}{R_{shunt}} \cdot I_{refcc}$

Note 3: $T_d = \ln \left(\frac{V_{th_high}}{V_{th_low}} \right) \cdot R_{ex} \cdot C_{ex} = R_{ex} \cdot C_{ex} \cdot K_{td}$

DESCRIPTION

This device typically drives a direct current motor servomechanism providing two extreme end positions and replaces end position switches or sensors.

For more details see the Timing diagram (Fig. 1) and the Application diagram (Fig. 2)

When the power supply is applied, or its polarity is inverted the motor is powered up (start point). The current of the motor reaches the start up value near to the stall current, always higher than the threshold value of the device (I_{TH}). A delay on the detection (T_D) permits the motor start up and the consequent decrease of the current.

During the free running phase, the current in the motor must always be lower the threshold I_{TH}. When the motor reaches the end of the run limit, the current increases reaching a value that, depending on the application, can be the stall value or can depend on some torque limiting friction (end point). Provided that this value is higher the programmed threshold I_{TH}, the motor is stopped after a time delay T_D, and the device goes into a low consumption standby status, ready to restart the motor for a new cycle if the polarity of the power supply is inverted (or power is switched off and on).

In any case, if the current exceeds the higher threshold I_{THCC}, the motor is immediately stopped because a short circuit is detected. The delay T_D

also permits the motor to overcome some small obstacle during the free run.

The threshold current for the running phase I_{TH} is obtained by comparing the voltage on an external sensing resistor (R_{SHUNT}) to a threshold voltage V_{TH}.

$$1) I_{TH} = V_{TH} / R_{SHUNT}$$

V_{TH} is constant in respect to the power supply voltage because in most applications, the end of run current is depending only on motor and the mechanic torque limiting device (friction current).

The threshold current for the short circuit detection is:

$$2) I_{THCC} = V_{THCC} / R_{SHUNT} \quad @ \quad V_{THCC} = 330mV \quad @ \quad V_{bat} = 12V$$

and depends intentionally on the supply voltage because of the same dependence of the stall current. The time T_D depends on two external components, capacitor C_{EX} and resistor R_{EX}. T_D is obtained by the following expression :

$$T_D = R_{EX} \cdot C_{EX} \cdot K_{TD}$$

K_{TD} is a constant typically of unit value.

The block diagram is shown on the first page. The change of the polarity between pins COM-MON and LIVE, needs the active bridge to supply the internal circuit. The internal supply voltage is available between pins V+ and GND and a storage and filter capacitor (100nF) must be connected between these pins. The output stage

consists of two DMOS transistors connected in series with common drain to act as a switch with the voltage applied in both direction. A charge pump takes the gates of the DMOS above the

supply voltage. The motor is controlled by the control 'logic low voltage' block that receives the motor status for the comparator. The 'charge C_{EX}' block controls the T_D delay.

Figure 1. Functional timing diagram.

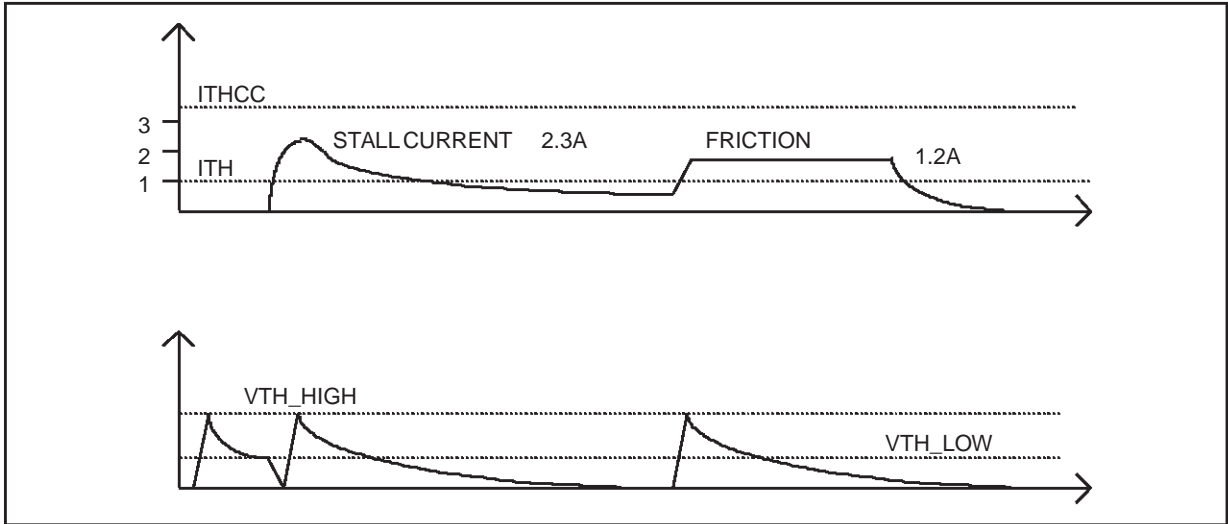
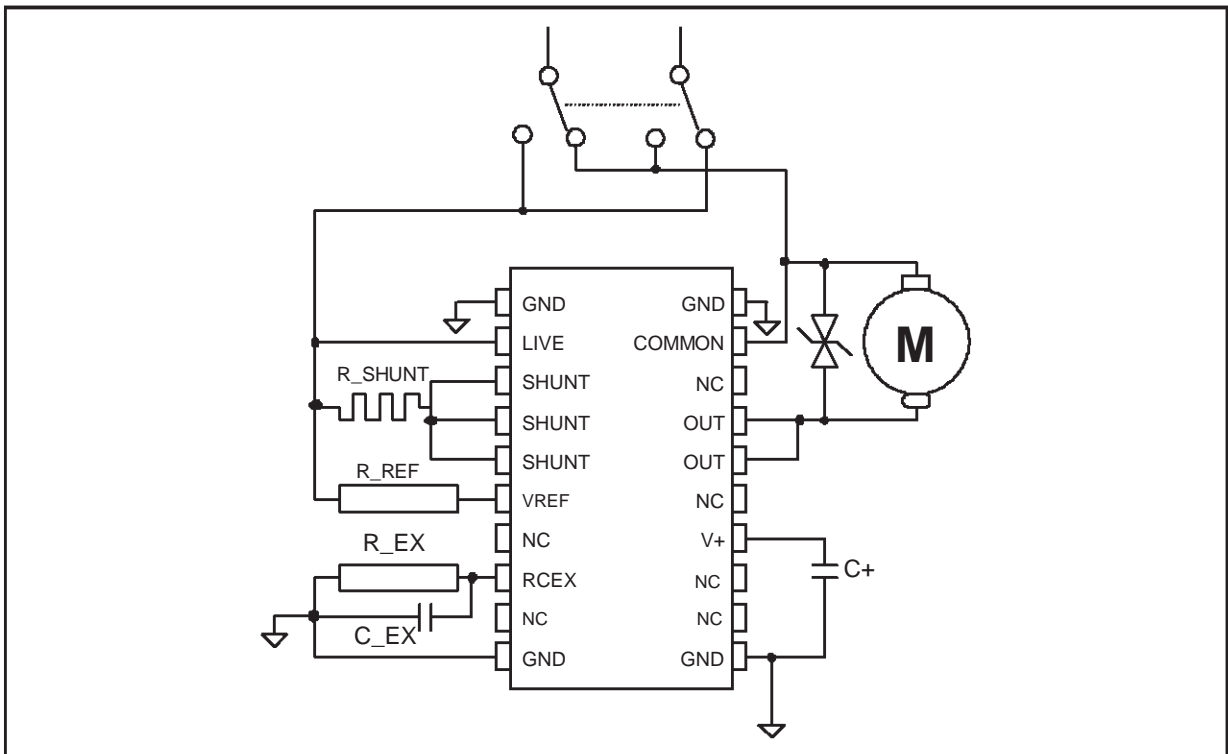

Figure 2. Application schematic diagram.



All the necessary external components are shown in the application diagram. It is important to shunt the motor with a device that limits the maximum over voltage to 40V. This is necessary when the power supply circuit is opened on motor power up. In this case the back E.M.F. must be clamped because there is no other free wheel current path.

DIM.	mm			inch		
	MIN.	TYP.	MAX.	MIN.	TYP.	MAX.
A			3.6			0.142
a1	0.1		0.3	0.004		0.012
a2			3.3			0.130
a3	0		0.1	0.000		0.004
b	0.4		0.53	0.016		0.021
c	0.23		0.32	0.009		0.013
D (1)	15.8		16	0.622		0.630
D1	9.4		9.8	0.370		0.386
E	13.9		14.5	0.547		0.570
e		1.27			0.050	
e3		11.43			0.450	
E1 (1)	10.9		11.1	0.429		0.437
E2			2.9			0.114
E3	5.8		6.2	0.228		0.244
G	0		0.1	0.000		0.004
H	15.5		15.9	0.610		0.626
h			1.1			0.043
L	0.8		1.1	0.031		0.043
N	10° (max.)					
S	8° (max.)					
T		10			0.394	

(1) "D and F" do not include mold flash or protrusions.
 - Mold flash or protrusions shall not exceed 0.15 mm (0.006").
 - Critical dimensions: "E", "G" and "a3"

OUTLINE AND MECHANICAL DATA

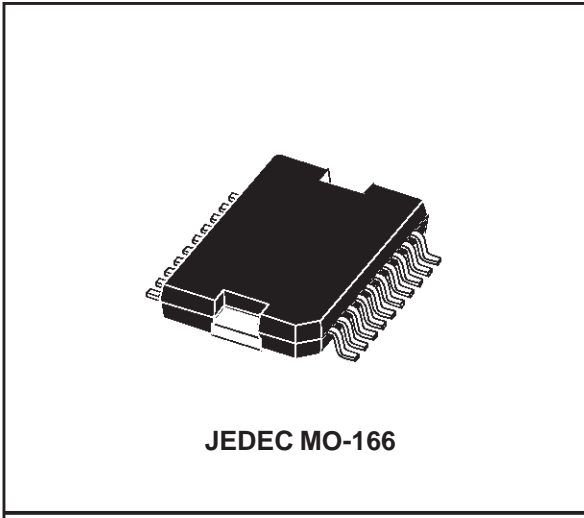

JEDEC MO-166

PowerSO20

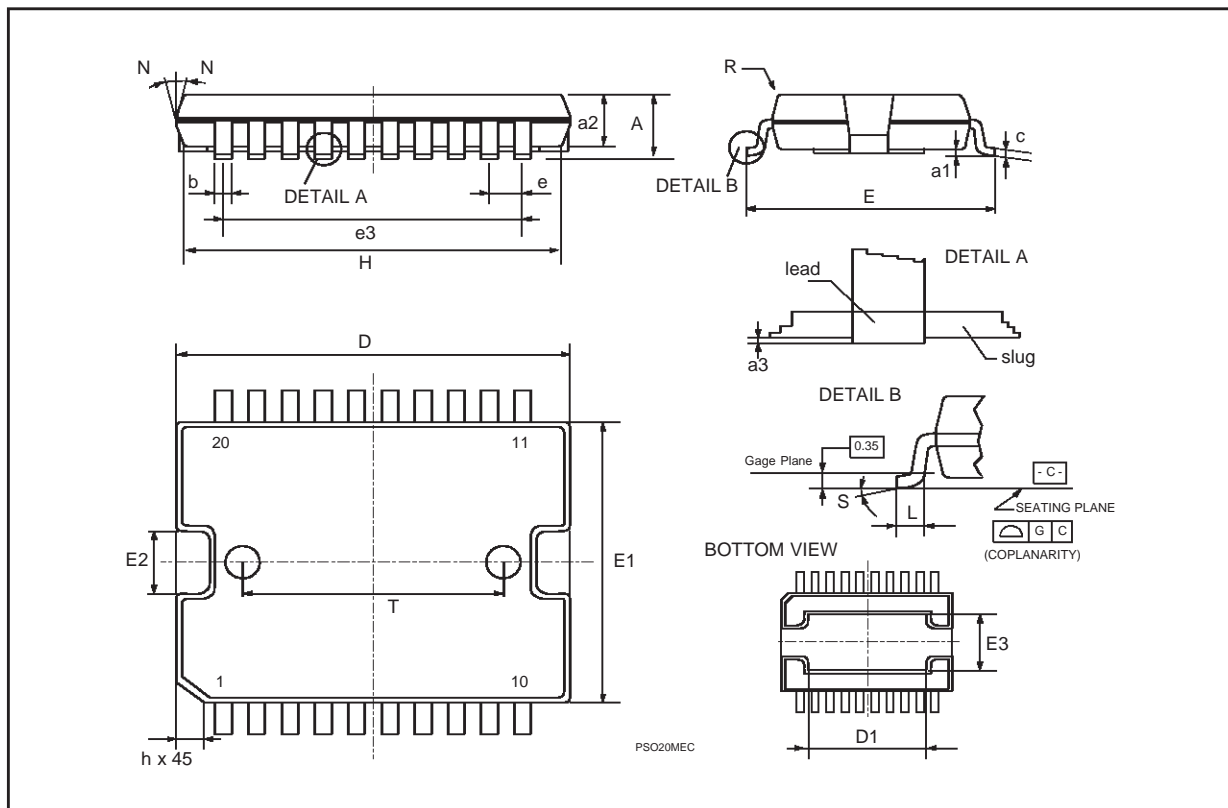

Information furnished is believed to be accurate and reliable. However, STMicroelectronics assumes no responsibility for the consequences of use of such information nor for any infringement of patents or other rights of third parties which may result from its use. No license is granted by implication or otherwise under any patent or patent rights of STMicroelectronics. Specification mentioned in this publication are subject to change without notice. This publication supersedes and replaces all information previously supplied. STMicroelectronics products are not authorized for use as critical components in life support devices or systems without express written approval of STMicroelectronics.

The ST logo is a registered trademark of STMicroelectronics

© 1998 STMicroelectronics – Printed in Italy – All Rights Reserved

STMicroelectronics GROUP OF COMPANIES

Australia - Brazil - Canada - China - France - Germany - Italy - Japan - Korea - Malaysia - Malta - Mexico - Morocco - The Netherlands - Singapore - Spain - Sweden - Switzerland - Taiwan - Thailand - United Kingdom - U.S.A.

<http://www.st.com>